



# HORIZON VHA 118SA

Processed Active Subwoofer

FBT elettronica SpA

Via Paolo Soprani 1 - 62019 RECANATI - ITALY Tel. 071 750591 - Fax. 071 7505920 - email: info@fbt.it - www.fbt.it

## APPLICATIONS

- Touring sound reinforcement
- Permanent installations in Theatres, Stadiums, Concert halls, Arenas.....
- Ideal for reinforcing and extending the low range of the VHA system.

## FEATURES

- Bass reflex active subwoofer
- Class D 2500W RMS with switching power supply
- 18" high excursion woofer with 4" coil
- Cabinet in 0,70" (18mm) birch plywood with anti-scratch varnish
- Easy transport by 6 aluminum handles and predisposition for 4 wheels (optional)
- 2 M20 stand supports positioned at the top and side
- Completely manufactured in Italy

## DESCRIPTION

FBT HORIZON VHA 118SA is an active subwoofer in bass reflex configuration equipped with a Class D amplifier capable of delivering a power of 2500W and with a 18" B&C woofer with 4" voice coil. The system achieves considerable sound pressure level for long periods of time, guaranteeing extremely clean, precise sound reproduction with reduced noise level thanks to a wide laminar air flow chord. FBT HORIZON VHA 118SA offers the possibility to choose between 6 completely rewritten pre-defined algorithms, which also include "Infra" and cardioid applications. The controls and connections panel has: Neutrik powercon connector for power supply with input and output, balanced input/output XLR connectors, delay control, 6 preset selector, signal level control, "VHA 112SA" switch that allows a perfect alignment in phase when in the configuration there is also the subwoofer VHA 112SA, three status leds (protection/limiter, peak and ON). The construction materials of FBT HORIZON VHA 118SA meet the highest professional standards to ensure maximum reliability; the cabinet is in birch plywood of 0,70" (18mm) with anti-scratch varnish, has six aluminum handles, predisposition for 4 wheels of 3,93" (100mm), two M20 stand sockets for horizontal or vertical use of the system and 4 support points set up to accommodate accessories in ground-stack configuration in conjunction with VHA 406A and VHA 112SA models. Ideal for extending and reinforcing low frequencies in combination with the VHA line array system

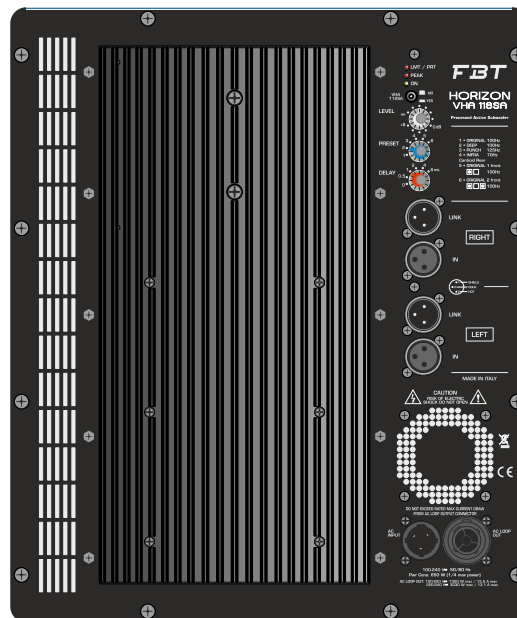

## PHYSICAL

Low Frequency Woofer	1 x 18" - 4" coil
Input Connectors	XLR with loop
Net Dimensions WxHxD	23,85" x 27,55" x 28,34" 606 x 700 x 720mm
Shipping Dimensions with pallet WxHxD	27,55" x 35,31" x 31,49" 700 x 897 x 800mm
Net Weight	143 lbs / 65 kg
Shipping Weight (with pallet)	165 lbs / 75 kg
Enclosure Material	0,70" birch plywood
Power cord	16,40 ft / 5 mt.

## PERFORMANCE

System Type	1way reflex active subwoofer
Built-in Amplifiers LF / HF	max.: 2500W RMS max. peak.: 5000W
Frequency Response	30Hz - preset dependent
Input Impedance	22kOhm
Maximum SPL ( cont/peak )	137/143dB half space
Dispersion	omnidirectional
Crossover Frequency	preset dependant
AC Power requirement	650 W (1/4 max power)

COLORS AVAILABLE BLACK



FBT ELETTRONICA SpA has the right to amend products and specifications without notice



# HORIZON VHA 118SA

Processed Active Subwoofer

FBT elettronica SpA

Via Paolo Soprani 1 - 62019 RECANATI - ITALY Tel. 071 750591 - Fax. 071 7505920 - email: info@fbt.it - www.fbt.it

## DIMENSIONAL DRAWING

ONLY FOR GROUND STACK CONFIGURATION

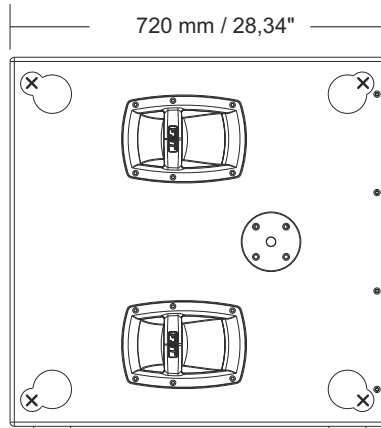
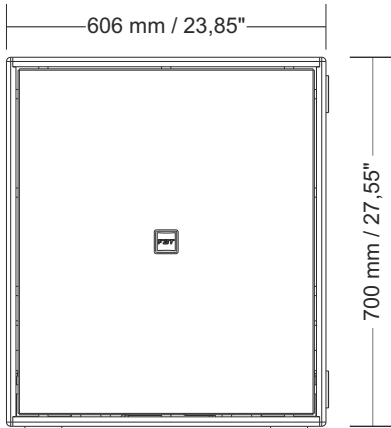

X Arranged for accessory mounting MS-F 210  
(Model MUSE 210LA on the sub)

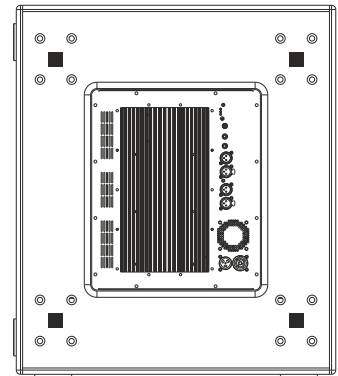

■ Arranged for 4" mounting optional wheels

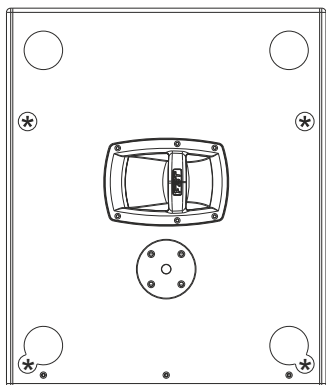

\* Arranged for accessory mounting VHA-B 406  
(Models HORIZON VHA406A and VHA112SA on the sub)



# HORIZON VHA 118SA

Processed Active Subwoofer

FBT elettronica SpA

Via Paolo Soprani 1 - 62019 RECANATI - ITALY Tel. 071 750591 - Fax. 071 7505920 - email: info@fbt.it - www.fbt.it

## ACCESSORIES

