



VERVE 112m

SOUND REINFORCEMENT MONITOR

APPLICATIONS

- Live Sound Reinforcement Floor Monitor
- Touring Systems, Clubs, Auditoriums, Theatres
- House of Worship, D.J. Booth Monitor
- Medium band P.A.
- Commercial Installations

FEATURES

- 0,59" baltic birch plywood cabinet, internally braced to prevent undesired resonance and vibrations
- 12" LF woofer with 2.5" voice coil, custom made for FBT
- 1" B&C HF compression driver with 1.7" voice coil
- 90° omnidirectional angle dispersion
- Input panel with 2 x Neutrik speakon NL4 jack
- High SPL capability: 129dB
- Wall bracket mount flange plate, 1.38" top-hat speaker stand socket, two integrated handles
- Available in white colour
- Completely Manufactured in Italy



Designed, Engineered
and Manufactured in ITALY

PRODUCT DESCRIPTION

The FBT VERVE112M passive speaker feature 0.59" Baltic birch plywood construction, covered in a scratch & scuff resistant black finish. The FBT VERVE 112M is a two way design incorporating a 12" custom woofer with 2.5" voice coil, 1" B&C compression driver with 1.7" voice coil. With a frequency range of 70Hz-18kHz the FBT VERVE 112M provides hi fidelity sound for both speech and music applications with a maximum SPL of 129dB. The rear panel provides two NL4 Neutrik Speakon female connectors. A front face steel grille protects the woofer from external damage. The optional mounting bracket allow the FBT VERVE 112M speakers to be surface mounted on walls or ceilings. A standard 1,38" speaker stand socket allows the FBT VERVE 112M to be mounted on speaker stands.

ELECTRONIC SPECIFICATIONS

System Type	2 Way
Recommended Amplifier	500W RMS
Long Term Power	250W
Short Term Power (IEC 268-5)	1000W
Nominal Impedance	8 Ohm
Frequency Response	70Hz - 18kHz (@-6dB)
Sensitivity	98dB (@1W, 1m)
Max SPL (cont/peak) (bi-amp)*	125dB / 129dB
Dispersion	90°
Crossover Frequency	2kHz
Recommended HP Filter	65Hz - 24dB oct.

PHYSICAL SPECIFICATIONS

Low Frequency Woofer	12" / 2.5" coil
High Frequency Driver	1" / 1.7" coil
Input Connectors	2 x speakon NL4
Net Dimensions (WxHxD) inch	21.65 x 12.59 x 16.14
Shipping Dimensions (WxHxD) inch	26.37 x 16.92x 19.68
Net Weight	36.59 lbs
Shipping Weight	42.76 lbs
Enclosure Material	0.59" baltic plywood
Grille	Steel with powder coat black or white paint finish

* CONT. SPL: free space, based on recommended amp rating and LF transducer average sensitivity data, 125mS time average
PEAK SPL: free space, based on short term applicable power rating and system peak sensitivity, 10mS time average



VERVE 112m

DIAGRAMS

Horizontal polar diagrams

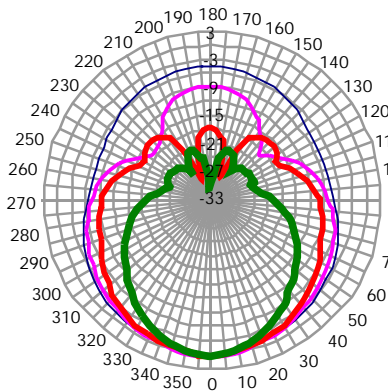

Horizontal polar diagrams

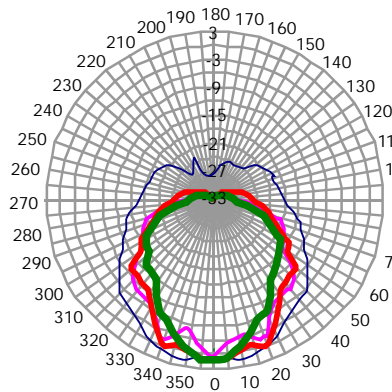
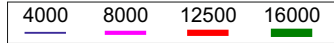

Vertical polar diagrams

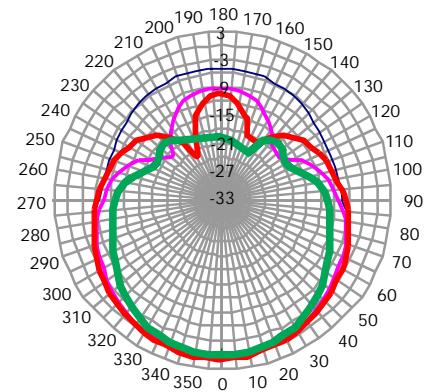

Vertical polar diagrams

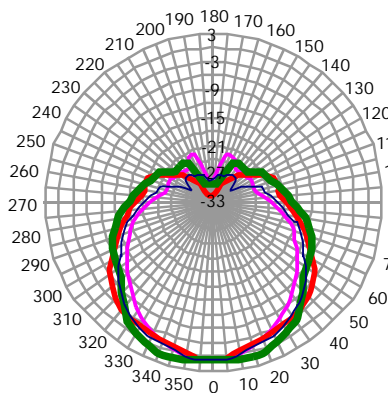
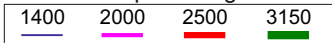

Vertical polar diagrams

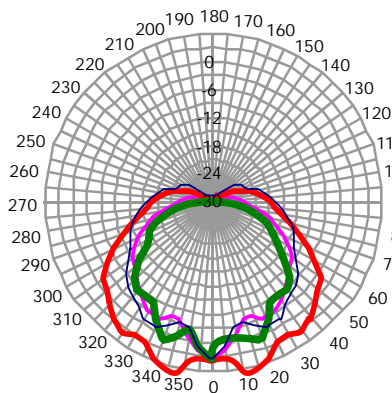
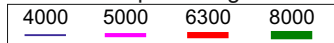

Vertical polar diagrams

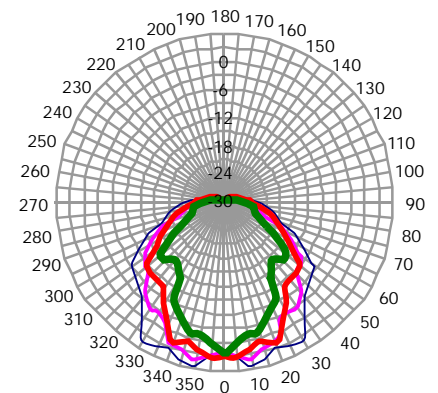

dB SPL FREQUENCY RESPONSE

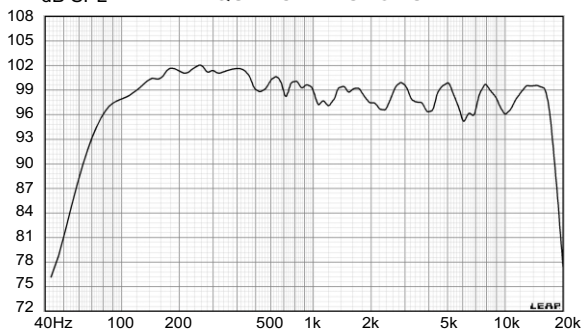

HORIZONTAL BEAMWIDTH (-6dB)

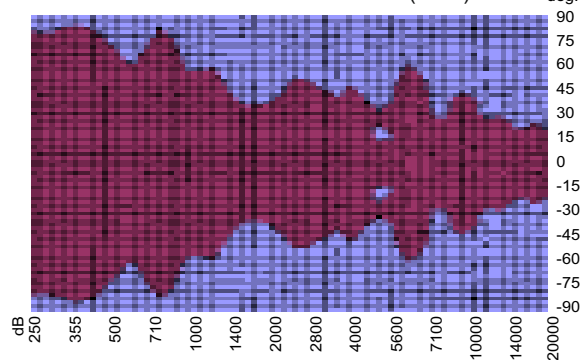



VERVE 112m

DIMENSIONAL DRAWING

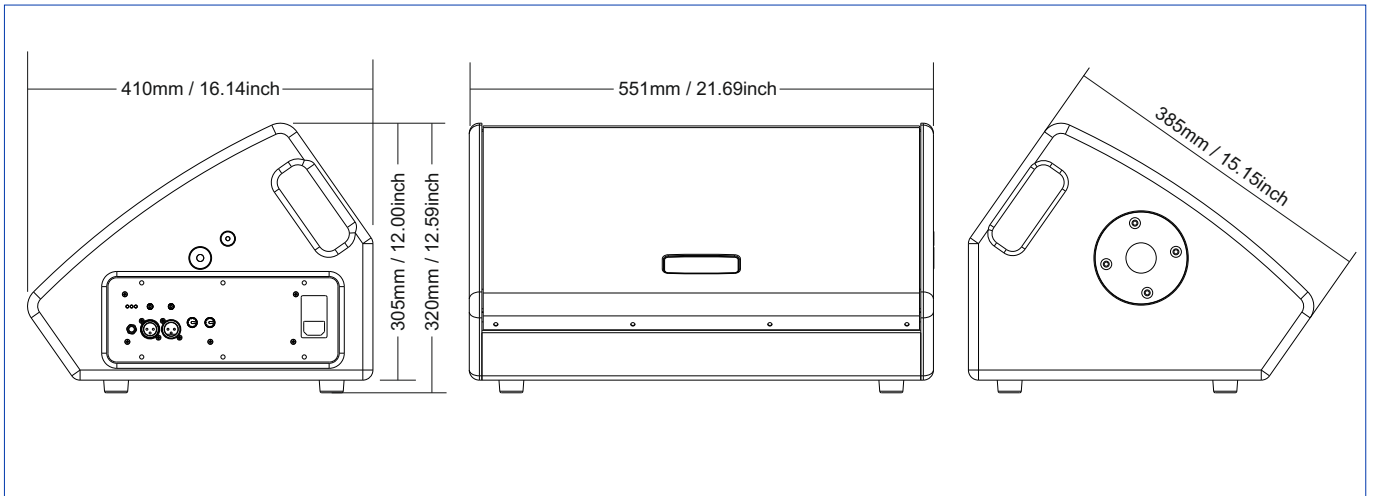

ACCESSORIES

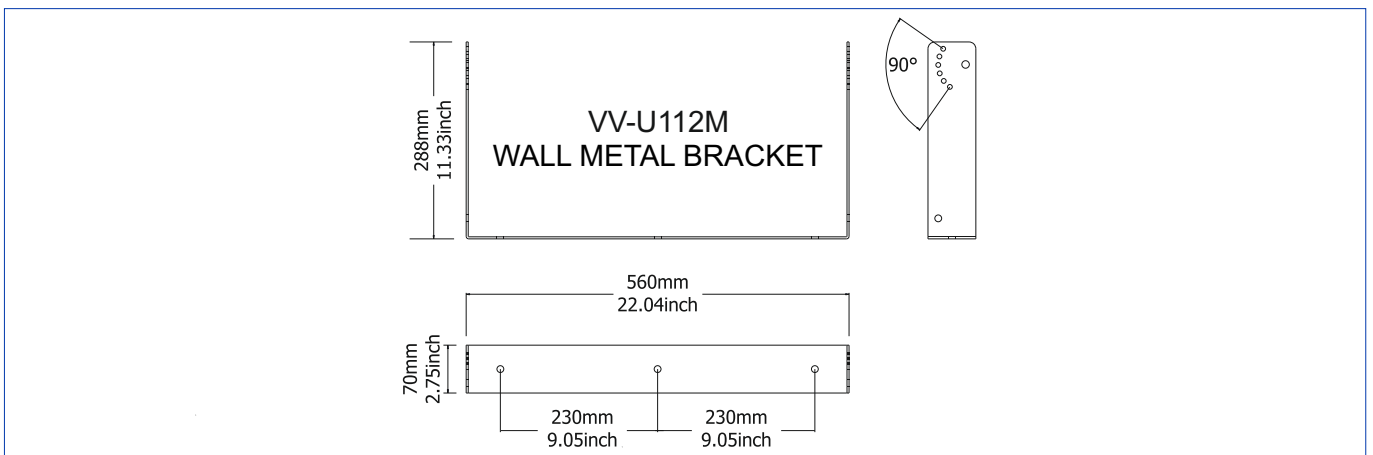

CONTROL PANEL

